

TECHNICAL MANUAL

Quality Uncompromised

ROTEL®

RD-870

STEREO CASSETTE DECK

TABLE OF CONTENTS

Chassis Layout	1
Alignment	2
Disassembly Diagram	3
Schematic Diagram	5
Wiring Diagram	6
Repair Parts List	7

THE ROTEL CO., LTD.

1-36-8 OHOKAYAMA, MEGURO-KU, TOKYO 152, JAPAN

ROTEL ELECTRONICS CO., LTD.

ROTEL BLDG., 3F, NO. 35, FUSING N. ROAD, TAIPEI, TAIWAN, REPUBLIC OF CHINA

MN20001330

Chassis Layout

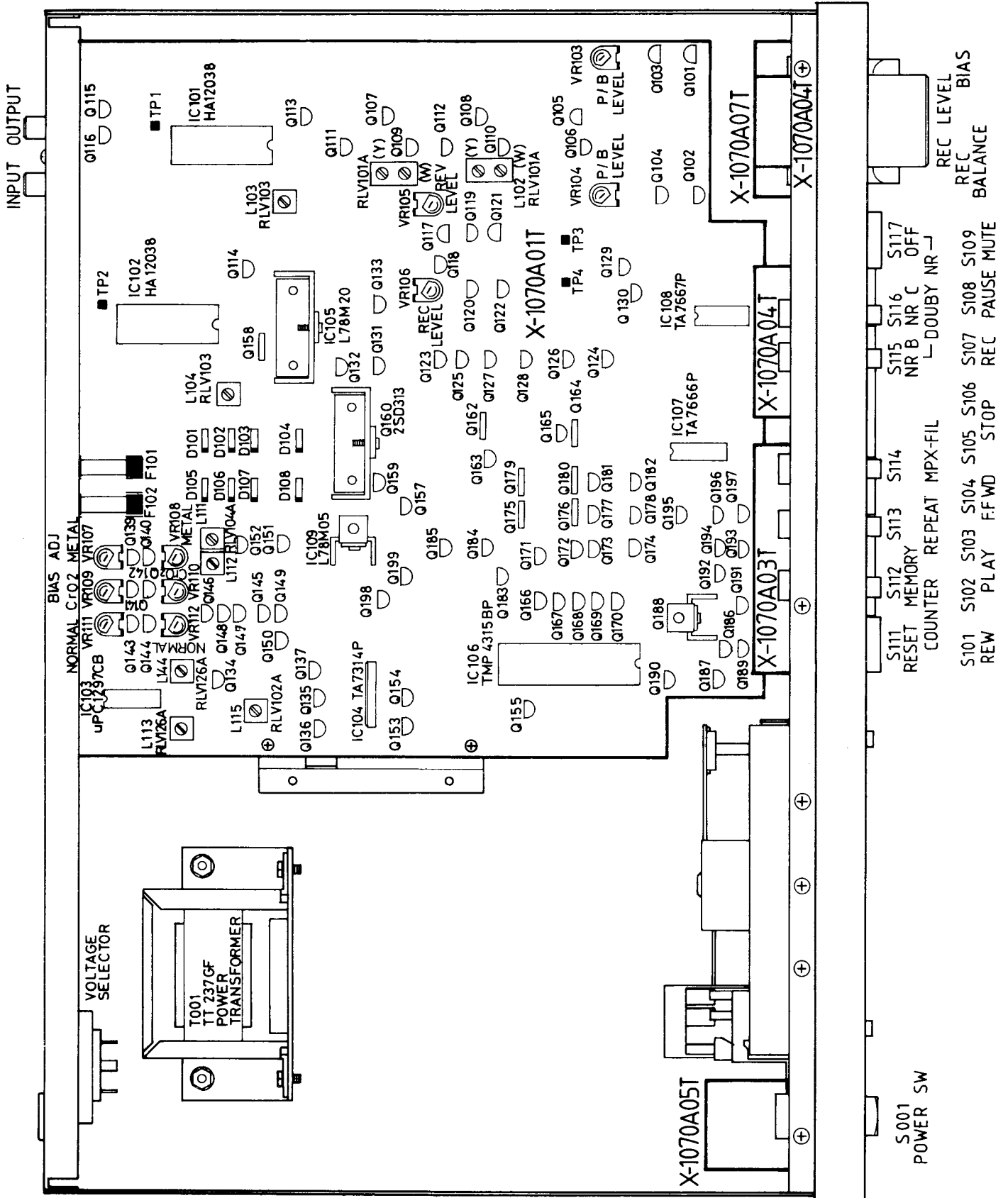

Recording System Adjustments

Instruments: Oscilloscope, Signal Generator, AC VTVM, Blank Tape

Conditions: Dolby NR... OFF

Adjustment Item	Coupling	Tape Selector	Adjust	Adjust for
Bias Trap	Rec. Level. MIN Oscilloscope C225(Lch) C226(Rch)	METAL	L111(Lch) L112(Rch)	Obtain Min, deflection on the Oscilloscope (10µS)
19KHz Filter	S.G (400Hz) ... LINE IN LINE OUT 580mV Changed S.G. to 19KHz Dolby NR OFF Rec. Level. MAX	FE	L101(Lch) L102(Rch)	AC VTVM reads - 32dB (Min)

REC/PB System Adjustments

Instruments: Signal Generator, T.H.D. Analyzer, Blank Tape

Conditions: Dolby NR... OFF, REC. Level... MAX, PLAY, REC. PAUSE... ON

Blank Tape: METAL... AC711, CO... AC512, FE... AC223

Adjustment	Conditions	Adjust	Adjust for
REC/PB Output Level	S.G (400Hz) LINE IN LINE OUT 580mV Release PAUSE Button	VR105(Lch) VR106(Rch)	Recording and Playback level difference must be within ± 0.5 dB
Distortion Check	S.G (400Hz) LINE IN LINE OUT 580mV T.H.D Analyzen ... LINE OUT Release PAUSE Button and playback it again	Check that distortion is within following range. a. METAL Tape under 2% b. CO Tape under 2% c. FE Tape under 2%	
If the distortion factor exceeds the above, recheck Bias Current Adjustment			
Frequency Response Check	METAL Tape insert it CD Tape insert it FE Tape insert it	35Hz ~ 16KHz ± 3 dB 35Hz ~ 15KHz ± 3 dB 35Hz ~ 14KHz ± 3 dB	
Frequency Response Adjust	S.G (400 Hz changed 10KHz) LINE IN LINE OUT 58mV Release PAUSE Button and playback it again	VR107(LCH) RV108(RCH) VR109(LCH) VR110(RCH) VR111(LCH) VR112(RCH)	REC/PB output level different between 400Hz-10KHz signal is within ± 1 dB

Playback System Adjustments

Instruments: Oscilloscope, AC VTVM, Frequency Counter, Test Tape

Conditions: Oscilloscope, AC VTVM, Frequency Counter... LINE OUT, Tape Selector... PE, Dolby NR... OFF

Adjustment Item	Test Tape	Adjust	Adjust for
Azimuth	TCC-153	REC/PB head screw	Obtain largest wave from on Oscilloscope for both channels (Fig. 1)
Dolby Level	TCC-130	VR103 (Lch) VR104 (Rch)	AC VTVM reads 580mV at TP.L (Lch) TP.R (Rch)
Playback EQ check	TCC-183A		Output Level difference between 125Hz 1 KHz and 10 KHz signal is within ± 2.5 dB
Tape Speed Deflection Check/ Tape Speed Adjust	TCC-112		Check that allowable margin of deflection at middle of or at the end of winding is in the range of $\pm 2\%$ (at 300Hz allowable margin of deflection of speed is 3045-2955) If Tape Speed deflection surpasses above range adjust speed of Motor (Fig. 2)

Key No.	Parts No.	Description	Key No.	parts No.	Description
1	KGD015630	Main Chassis	62	SEE3053511	Screw ⌀ M2.5 × 10
2	SIE0800808	Sensor P.C.B.	63	30MSW1250	Leaf Switch
3	SEE3053501	Flat Tapping Screw	64	SIE0902501	Lamp Holder Ass'y
4	SIE1600203	Breaker	66	KGE015566	Reel Ass'y
5	SIE1800401	Breaker Rubber	78	SIE2500101	Bracket, Tape Guide
6	SEE3053507	Screw ⌀ M2.5 × 4 Bind	79	SEE2133401	Screw ⌀ M2 × 3.2 Truss Tapping
8	SIE3600201	Steel Ball	80	SIE2501301	Bracket, Tape Guide
9	KGE015410	Head Base Chassis	85	SIE1901301	Side Chassis (R)
10	SID1100201	Head Support	86	SIE1901201	Supporting Plate
11	SIE2401101	Head Alignment Spring	87	SIE2900402	Holder (R)
12	307751014	R/P Head	88	SIE2900502	Holder (L)
13	308860103	E Head	89	SEE3055201	Screw ⌀ M2.6 × 8
14	SIE3400801	Wire Clamp	90	KGE015370	Side Chassis (L), Damper
15	SEE3053806	Screw ⌀ M2 × 12 Bind	91	KGE015141	Release Lever Ass'y
16	SEE3053601	Screw ⌀ M2 × 14	92	SIE2403301	Spring
17	SIE6700601	Connector Ass'y (6P)	94	KGE015064	Damper Unit
18	SIE6700701	Connector Ass'y (2P)	95	SIE2403201	Spring
19	SIE3600102	E Ring	96	SIE3601201	CS Ring
20	SIE2501701	Bracket	97	SIE0703002	Ornamental Plate
21	KGE015173	Motor Chassis	100	SEE3053512	Screw ⌀ M2.5 × 3.5
22	KGE015225	Reel Motor Ass'y	101	AW00000332	Acrylic Door Plate
22-1	30BFS9B03	Reel Motor	102	SW00000434	Ornamental Screw
22-2	SIE3300201	Shaft Bush			
22-3	SEE1022803	Washer			
22-4	SIE2404901	Spring			
22-5	KGE015550	Idler Ass'y			
22-6	SIE1700102	Wheel			
22-7	SIE2601402	Motor, Gear			
23	KGD103702	Switch Support			
24	KGD103273	Leaf Switch			
25	SIE3600811	Cylinder Bush			
26	KGE103312	Screw ⌀ M2 × 30			
27	KGE104076	Lead Wire			
29	SEE3053701	Binding Screw			
30	SIE2500302	Back Tention			
31	SEE1022805	Washer			
32	KGE015631	Reel Table			
33	SEE1022802	Washer			
34	SIE2000602	REC Lever			
35	KGE015176	Bracket, Motor			
36	30VA700B02	PAD Motor			
37	SEE3056601	Screw ⌀ M2 × 3			
38	SID3800601	Leaf Switch			
39	SID2600101	Cam Gear			
40	SEE3053506	Screw ⌀ M2.5 × 20			
41	SIE4201101	Printed P.C.B.			
42	KGE104074	Connector Ass'y (12P)			
43	KGD103805	Detect Lever			
44	KGE103350	Spring			
45	SIE3600101	E Ring			
46	KGE103913	Connector Ass'y (4P)			
47	SEE3054501	Screw ⌀ M2 × 4			
48	SIE2101502	Cover Plate			
49	30A2NLB01	DD Motor			
50	SIE3600203	Steel Ball			
51	SIE2501001	Head Press Plate			
52	SIE3601401	Nut			
53	KGE015183	Pinch Arm Ass'y			
54	SIE2403701	Spring			
55	22145	E Ring			
56	SIE2100201	Lock Plate			
57	SIE2300401	Cylinder Bush			
58	SIE2400701	Spring			
59	SEE3053504	Screw ⌀ M2.5 × 10			
60	SIE3301401	Cable Tie			

Disassembly Diagram

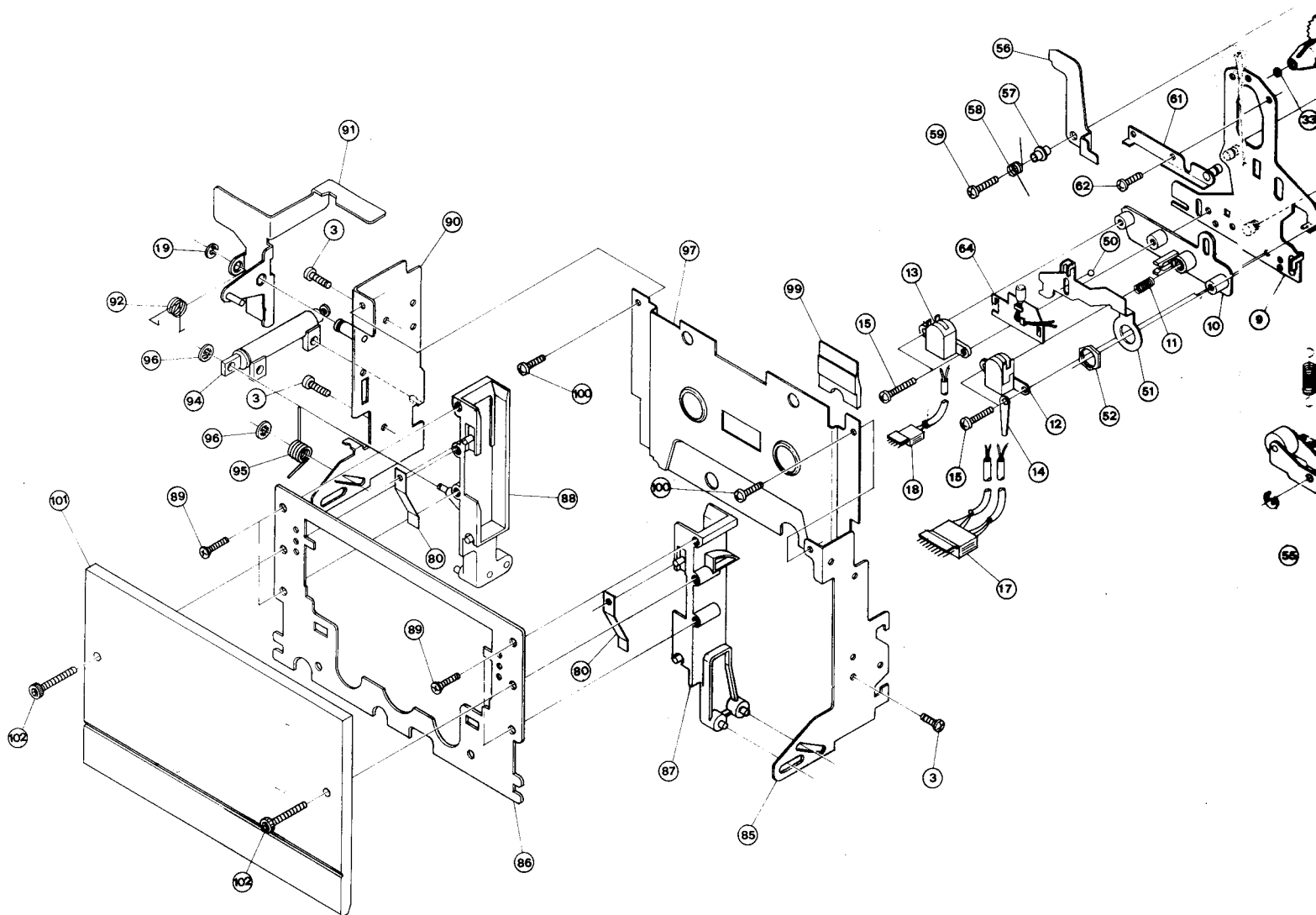

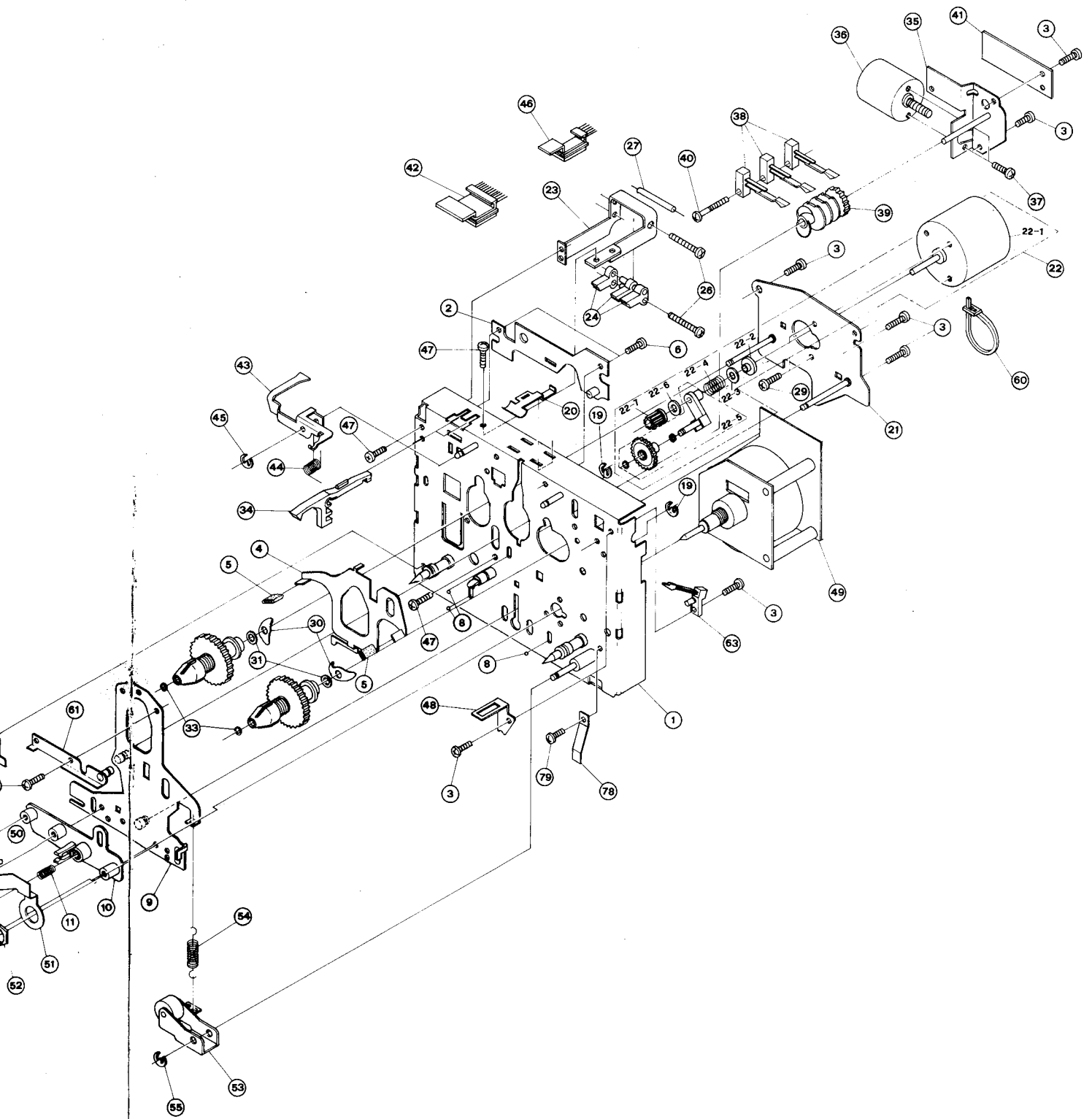

Schematic Diagram

NOTE: PARTS AND CIRCUIT SUBJECT TO CHANGES FOR IMPROVEMENT WITHOUT PRIOR NOTICE.

ADD 10K RESISTOR FOR 60Hz CLOCK REPEAT

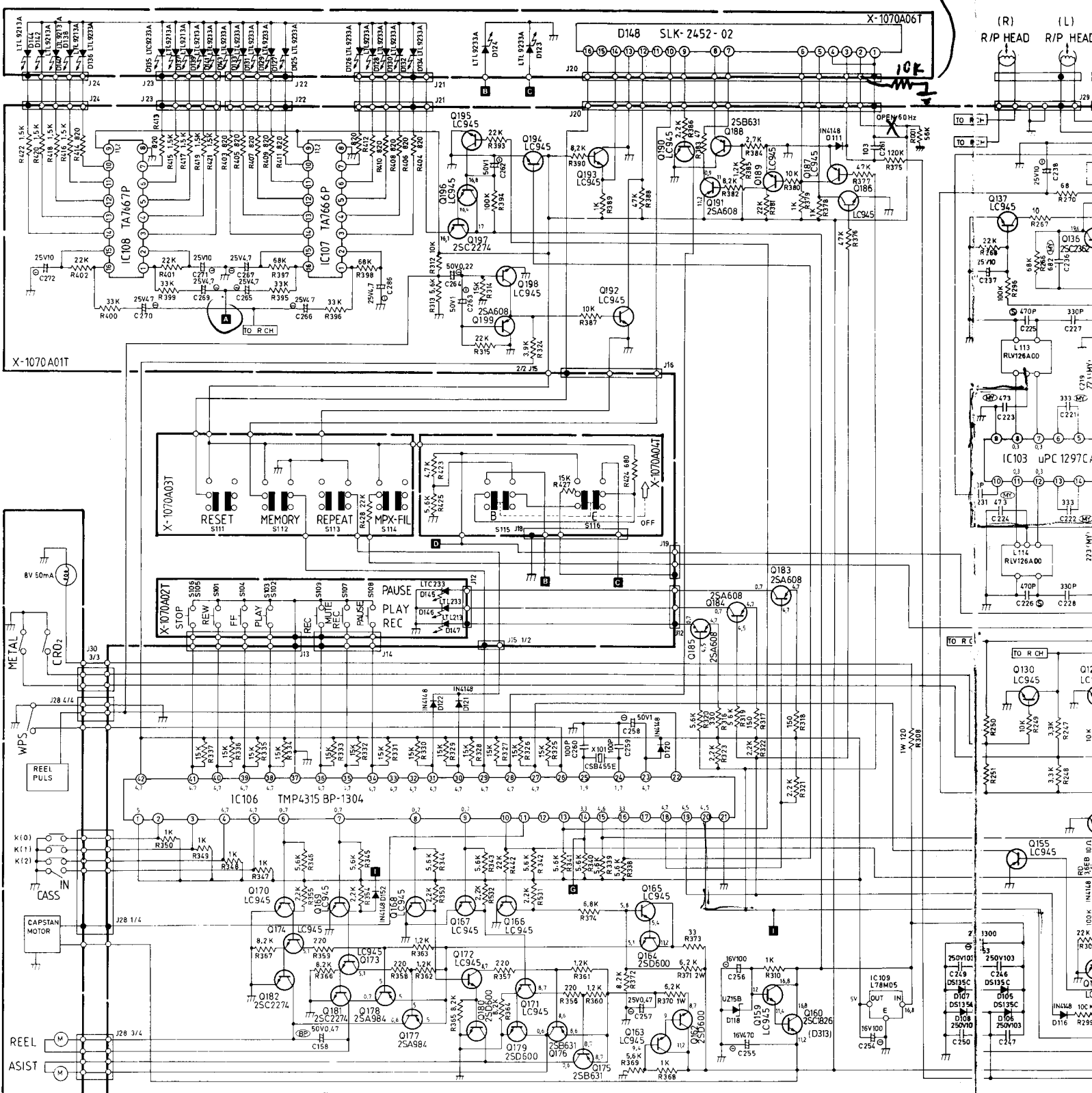

Repair Parts List

Schematic Location	Parts No.	Description
TRANSISTORS, DIODES AND IC'S		
Q101, 102	TR30000108	2SC1571 (E, F), Play Amp
Q103, 104	TR30000108	2SC1571 (E, F), Play Amp
Q105, 106	TR30000327	2SC536G, Muting
Q107, 108	TR30000327	2SC536G, Amp. Buffer
Q109, 110	TR30000248	LC945, Mpx Filter
Q111, 112	TR30000248	LC945, Mpx Filter
Q113, 114	TR30000327	2SC536G, Muting
Q115, 116	TR30000327	2SC536G, Muting
Q117, 118	TR30000327	2SC536G, Muting
Q119, 120	TR30000108	2SC1571 (E, F), Rec. Amp.
Q121, 122	TR10000023	2SA1016 (G, H), Rec. Amp.
Q123, 124	TR30000248	LC945, Muting
Q125, 126	TR30000248	LC945, Muting
Q127, 128	TR30000248	LC945, Muting
Q129, 130	TR30000248	LC945, Muting
Q131, 132	TR30000248	LC945, Muting
Q133	TR10000126	2SA608K (F, G) Muting ✓
Q134	TR30000121	2SC2274 (E, F), Buffer ✓
Q135, 136	TR30000212	2SC2362 (G, H), O.S.C. TR.
Q137	TR30000248	LC945, O.S.C. TR.
Q139, 140	TR30000248	LC945, Muting
Q141, 142	TR30000248	LC945, Muting
Q143, 144	TR30000248	LC945, Muting
Q145, 146	TR30000327	2SC536G, Control TR.
Q147, 148	TR30000327	2SC536G, Control TR.
Q149	TR30000248	LC945, Control TR.
Q150	TR30000327	2SC536G, Control TR. ✓
Q151, 152	TR30000327	2SC536G, Muting
Q153, 154	TR30000248	LC945, Muting
Q155	TR30000248	LC945, Muting
Q157	TR30000248	LC945, Muting
Q158	TR40000069	2SD600K (E, F), Regulator
Q159	TR30000248	LC945, Regulator
Q160	TR30000029	2SC1826 (O, Y), Regulator
Q162	TR40000069	2SD600K (E, F), Control TR
Q163	TR30000248	LC945, Control TR
Q164	TR40000069	2SD600K (E, F), Control TR
Q165	TR30000248	LC945, Control TR
Q166 - 174	TR30000248	LC945, Control TR
Q175, 176	TR10000047	2SB631K (E, F), Control TR
Q177, 178	TR10000140	2SA984K (E, F), Control TR
Q179, 180	TR40000069	2SD600K (E, F), Control TR
Q181, 182	TR30000121	2SC2274 (E, F), Control TR
Q183 - 185	TR10000126	2SA608K (F, G), Control TR
Q186, 187	TR30000248	LC945, Control TR
Q188	TR10000047	2SB631K (E, F), Control TR
Q189, 190	TR30000248	LC945, Control TR
Q191	TR10000126	2SA608K (F, G) Control TR
Q192 - 196	TR30000248	LC945, Muting
Q197	TR30000121	2SC2274 (E, F), Muting
Q198, 199	TR30000248	LC945, Muting
Q200	TR30000327	2SC536G, Control TR
IC101, 102	IC00000469	HA12038, DOLBY NR System ✓
IC103	IC00001607	μPC1297CA, DOLBY HX PRO System ✓
IC104	IC00001085	TA7341P, INTERPROGRAM SENSOR ✓
IC105	IC00000548	L78M20, Regulator
IC106	IC00001619	TMP4315BP-1304, Micro Process ✓
IC107	IC00000410	TA7666P, Level Indicator Driver
IC108	IC00000445	TA7667P, Level Indicator Driver
D101 - 108	DD10000068	DS135C, Rectifier
D109	DD20000107	UZ3.6(B), Zener Regulator
D110	DD10000100	IN4148, Diode
D111 - 117	DD10000100	IN4148, Diode
D118	DD20000090	UZ15B(L), Zener Regulator
D120 - 122	DD10000100	IN4148, Diode
D123, 134	DD40000617	LTL-9233A GREEN, LED
D135 - 138	DD40000563	LTL-9213A RED, LED
D139, 140	DD40000617	LTL-9233A GREEN, LED

Schematic Location	Parts No.	Description
D141 - 144	DD40000563	LTL-9213A RED, LED
D145, 146	DD40000770	LTL-233 GREEN, LED
D147	DD40000653	LTL-213 RED 5F, LED
D148	DD40000800	SLK-2452-02, Counter LED
D149 - 151	DD10000100	IN4148, Diode
COILS, VARIABLE RESISTORS, SWITCHES AND OTHERS		
L101, 102	LC31010103	RLV101A00, Coil
L103, 104	LC31030102	RLV103A00, Coil DOLBY C
L105, 106	LM00000395	8.2mH, Micro Inductor
L107, 108	LM00000371	3.9mH, Micro Inductor
L109, 110	LM00000413	3.3mH, Micro Inductor
L111, 112	LC31040107	RLV104A00, Coil, Trap
L113, 114	LC31260004	RLV126A00, Coil, Hxpro
L115	LC31020108	RLV102A00T, Coil, OSC
VR103, 104	RV20000235	08-301 50KB, P/B Level
VR105, 106	RV20000193	08-301 10KB, REC Level
VR107, 108	RV20000193	08-301 10KB, Metal
VR109, 110	RV20000272	08-301 5KB, Cr02 ✓
VR111, 112	RV20000338	08-301 2.3KB, Normal ✓
VR113	RV10000342	4TR-1439 250KW, REC Balance Control ✓
VR114	RV10001085	4TR-2281 10KB, Bias Control ✓
VR115, 116	RV10000627	4TR-1966 50KAX2, Volume Control ✓
T001	PT14870096	TT-237-GF, Power, Transformer
S101 - 109	SH60000070	Key Board Switch, Rew, Play, F, FWD, Stop, REC, Pause, Mute
S111 - 114	SH14000172	4 Key Push Switch, Reset, Memory, Repeat MPX-FIL ✓
S115, 116	SH13000292	3 Key Push Switch, DOLBY NR B, DOLBY NR C. OFF. ✓
S001	SH40000120	Power Switch, C-3600 B-T
F101	FU12000148	Fuse, 250V 0.75A UL
	FU23000153	Fuse, 250V 800mA S
F102	FU12000033	Fuse, 250V 1.5A UL
	FU11000025	Fuse, Long 250V 1.5A
	FU21000034	Fuse, Mini 1.5A
	FU23000116	Fuse, 250V 1.6A S